



Deuschmann Automation

Cam Controls | Fieldbus Gateways | Industrial Ethernet Products

Instruction manual Universal Fieldbus-Gateway UNIGATE[®] IC - Ethernet



Art.-Nr.: V3284E

Deuschmann Automation GmbH & Co. KG Carl-Zeiss-Str. 8 D-65520 Bad Camberg

Tel: +49-(0)6434-9433-0 Hotline: +49-(0)6434-9433-33 Fax: +49-(0)6434-9433-40

Internet: <http://www.deuschmann.de>

1	General introduction	9
2	The UNIGATE® IC	10
2.1	Technical introduction	10
2.2	Availability	10
2.3	Firmware	10
2.4	The serial standard interface	10
2.5	The synchronous interface	10
2.6	The Debug-interface	10
2.7	UNIGATE® IC hardware survey	11
3	Hardware design.	12
3.1	Ports	12
3.2	Pinout	12
3.2.1	-Boot enable	13
3.2.2	Load out	13
3.2.3	Data out	13
3.2.4	Data In	13
3.2.5	Load In.	13
3.2.6	Clock.	13
3.2.7	-Reset In	13
3.2.8	LED-EN	13
3.2.9	-Config Mode	13
3.2.10	DbgTX, DbgRx.	13
3.2.11	TE	14
3.2.12	TX, RX.	14
3.3	Software	15
3.4	Basic line of proceeding	15
3.5	Connection examples	15
3.6	Layout examples	18
3.7	Handling (mounting the UNIGATE IC® on the carrier board)	20
4	The serial interface	21
4.1	Overview	21
4.2	Initialization of the serial interface	21
4.3	Use of the serial interface	21
4.4	Further operation modes	21
5	Synchronous interface	22
5.1	Overview of the synchronous serial interface	22
5.2	Script-example	22
6	The Debug-interface.	23
6.1	Overview of the Debug-interface	23
6.2	Starting in the Debug-mode	23

6.3	Communication parameter for the Debug-interface	23
6.4	Possibilities with the Debug-interface	23
6.5	Commands of the Debug-interface	23
7	Script and configuration	24
7.1	Overview	24
7.2	The configuration mode	24
7.3	Update the script	24
7.4	Configuration of the UNIGATE® IC	24
7.4.1	Ethernet	24
7.4.2	RS232/RS485/RS422	24
8	Generating a script	25
8.1	What is a script?	25
8.2	Memory efficiency of the programs	25
8.3	What can you do with a script device?	25
8.4	Independence of buses	25
8.5	Further settings at the gateway	25
8.6	The use of the Protocol Developer	26
8.7	Accuracies of the baud rates at UNIGATE® IC	26
8.8	Script processing times	27
9	Setting the Ethernet-address	28
10	Error handling at UNIGATE® IC.	29
11	Firmware-update	30
11.1	Overview	30
11.2	Starting in firmware-update-mode	30
11.2.1	Adjustment by hardware	30
11.2.2	Adjustment by software	30
11.3	Execution of the firmware-update	30
11.4	Note on safety	30
11.5	Operation mode of the IC	30
12	Technical data	31
12.1	Mechanics of the UNIGATE® IC	31
12.1.1	General dimensions of UNIGATE® IC.	31
12.1.2	Dimensions UNIGATE® IC (Ethernet only).	31
12.2	Technical data UNIGATE® IC-Ethernet	32
13	Accessory	33
13.1	Adapter RS232	33
13.2	Adapter RS485	33
13.3	FirmwareDownloadTool (FDT)	33
13.4	Protocol Developer	33

13.5	Developerkit UNIGATE® IC-AB IC	33
13.5.1	Developerboard UNIGATE® IC-AB	33
13.5.2	Quick start	34
14	Appendix	35
14.1	Explanations of the abbreviations	35
14.2	basis board	36
14.2.1	Overview basis board Ethernet	36
14.2.2	Connectors of the basis board.	40
14.2.2.1	Connector to the external device (RS-interface).	40
14.2.2.2	Ethernet connector.	40
14.2.2.3	Power supply of the basis board.	40
14.2.2.4	Shield terminal lead	41
14.2.3	Rotary coding switches	41
14.2.3.1	Slide switch (RS485/RS232 interface).	41
14.2.3.2	Slide switch (RS485 termination)	41
14.2.4	Wiring diagram UNIGATE® IC-basis board Ethernet	42
15	Representation of the data in Ethernet.	45
15.1	Network-addresses, network-connections	45
15.2	TCP-connection setup	45
15.3	Data exchange	45
15.3.1	TCP or UDP?	45
15.4	TCP/IP-deviations from the standard	45
16	Servicing	47
16.1	Downloading PC software, Script examples etc.	47

Disclaimer of liability

We have checked the contents of the document for conformity with the hardware and software described. Nevertheless, we are unable to preclude the possibility of deviations so that we are unable to assume warranty for full compliance. The information given in the publication is, however, reviewed regularly. Necessary amendments are incorporated in the following editions. We would be pleased to receive any improvement proposals which you may have.

Copyright

Copyright (C) Deutschmann Automation GmbH & Co. KG 1997 – 2013. All rights reserved. This document may not be passed on nor duplicated, nor may its contents be used or disclosed unless expressly permitted. Violations of this clause will necessarily lead to compensation in damages. All rights reserved, in particular rights of granting of patents or registration of utility-model patents.

1 General introduction

In the past the integration of a fieldbus connection required an enormous effort from the progress engineers. On account of the large variety of communication systems it is not enough to compile the right combination of communication hardware; due to their standards and fundamentals different busses also require the corresponding skills of the engineers.

This does not apply in case of the UNIGATE® IC by Deutschmann Automation any more. All digital functions, software, stack and driver as well as optocoupler are integrated on a UNIGATE® IC in correspondence with the standard. In addition to the reduction of the required size, also different fieldbusses can easily be integrated.

Through the flexible firmware of UNIGATE® IC no software-changes are required on the side of the customer!

Since 1997 Deutschmann Automation has experience in the field of fieldbus gateways; this enormous experience results in the UNIGATE® IC as a consistent sequel of this successful product line.

Terminology

In the entire document and in all parts of the software that is to be used, the terms Input and Output are used. Input and Output are ambiguous, always depending on the viewpoint. We see the fieldbus as central interface and as integral component of your device; therefore in all places it is always referred to data from the viewpoint of the Slave, that is Input data, as data from the Master to the Slave - regardless of the used bus.

Representation of numbers

Numbers in decimal format are always represented without prefix and without suffix as well. Hexadecimal numbers are always marked with the prefix 0x.

2 The UNIGATE® IC

2.1 Technical introduction

The UNIGATE® IC by Deutschmann Automation contains all components that are required for the communication in a fieldbus in one single module. Therefore a developer does not have to take care for that detail any more, only a hardware redesign is necessary in order to integrate the UNIGATE® IC and the required plug connectors.

2.2 Availability

The module is available as Ethernet. Further fieldbusses are either planned or being worked on. They will only differ in the connections of the busses. The meaning of the general pins 1 - 9 as well as 24 and 26 - 32 will remain unchanged also for further fieldbus implementations.

You can find an up-to-date list for all UNIGATE ICs under:

<http://www.deutschmann.de>.

2.3 Firmware

UNIGATE® IC is programmed via scripts. On principle any script, that has been developed for a UNIGATE® SC, can also be operated on the UNIGATE® IC.

2.4 The serial standard interface

Intelligent devices, that already feature a micro controller or a microprocessor, are generally supplied with a serial asynchronous interface with a TTL-level. It is directly connected with the TTL-interface of the UNIGATE® IC. For more information on this serial interface see chapter 4 on page 21.

2.5 The synchronous interface

In addition to the standard interface there is also the possibility of the synchronous input and output. That way for instance digital IOs can be connected through shift register components or also analog IOs can be connected through a DA-converter with serial in-/output. For synchronous IOs 256 signals at the most can be used (256 bit). Wiring examples can be found in chapter 3.5 and for software examples see chapter 5.1. It is also possible to build, for instance digital or analogous I/O-modules, with the customer's device not being equipped with an own controller. The fieldbus IC is also operable autonomously without that controller.

2.6 The Debug-interface

The UNIGATE® IC features a Debug-interface, which allows to process a script step by step and also to monitor or manipulate data. This is indispensable for the development of a script. Usually a script is developed with the software Protocol Developer. For more details take a look at the instruction manual Protocol Developer.

All interfaces can independently be used at the same time.

2.7 UNIGATE® IC hardware survey

The hardware of the UNIGATE® IC consists of some few standard components. The picture below shows the functional structure of the IC.

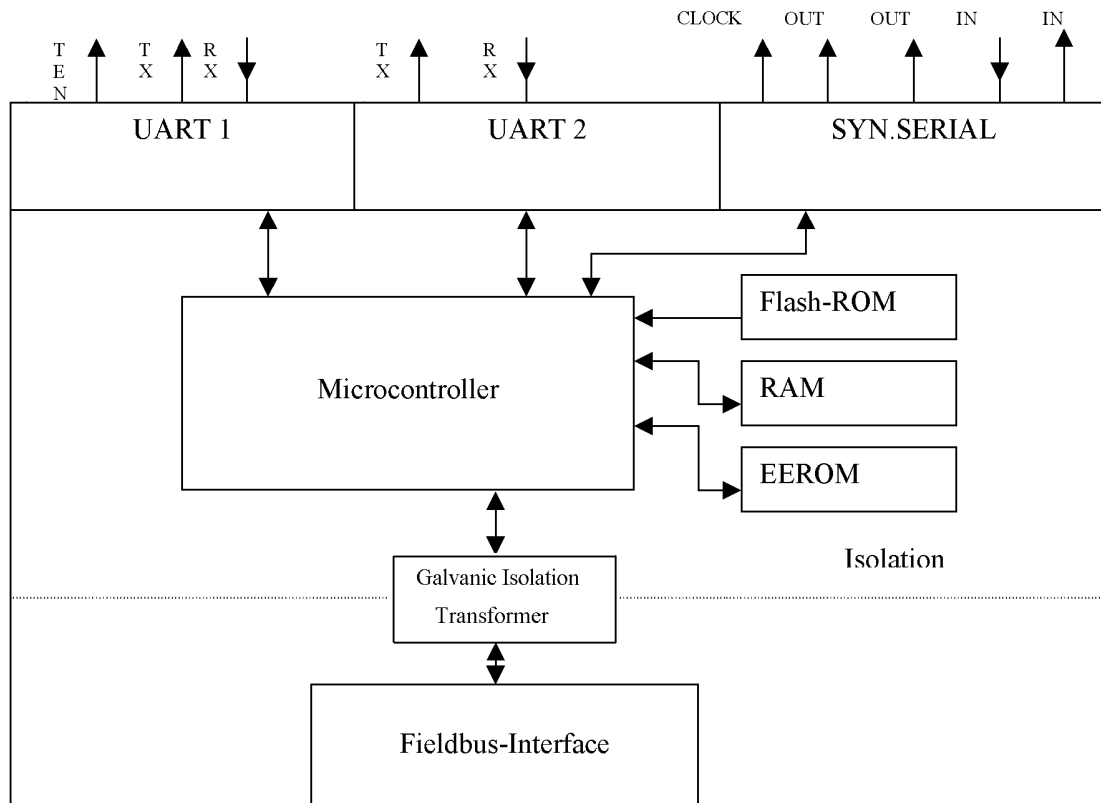

3 Hardware design

This chapter gives basic advise, that is required in order to load UNIGATE® IC into your own hardware designs. In the following all ports of UNIGATE® IC are described in detail.

3.1 Ports

UNIGATE® IC features 32 pins in its layout as a DIL 32 component. Pin 10 -12 and 21 - 23 as well are not wired due to the electrical isolation. The exact mechanical dimensions can be taken from chapter 12 on page 31.



In the layout boreholes for ALL 32 pins have to be planned.

3.2 Pinout

Pin	Technical specifications	Name	Description	Remark
1*	5V ± 5% < 250mA	Vcc	+ 5 V voltage supply	
2	IN _{Logic}	-BE	boot enable	
3	OUT _{Driver}	Load out	strobe signal for synchronous, serial interface	
4	OUT _{Driver}	Data out	output data for synchronous, serial interface	
5	IN _{Logic}	Data in	input data of the synchronous, serial interface	internally pulled up with 10 kΩ
6	OUT _{Logic}	Load in	input data of the synchronous, serial interface; alternatively strobe signal of the output data	
7	OUT _{Driver}	Clock	clock pulse signal for synchronous, serial interface	
8	IN _{Reset}	-Reset in	reset-input of the IC	internally pulled up with 100 kΩ
9*	connected to pin 1	Vcc	+ 5 V voltage supply	
10-12	nc	nc	no pin	
13	according to norm	RJ45	Ethernet-signal RX-	galvanically isolated insulation voltage 1000 Vrms
14	according to norm	RJ45	Ethernet-signal RX+	galvanically isolated insulation voltage 1000 Vrms
15	according to norm	RJ45	Ethernet-signal TX-	galvanically isolated insulation voltage 1000 Vrms
16	according to norm	RJ45	Ethernet-signal TX+	galvanically isolated insulation voltage 1000 Vrms
17	according to norm	LED-LAN	Network data communication	
18	according to norm	LED-LINK	Ethernet linkpulses found	
19+20	according to norm	nc	not connected	
21-23	nc	nc	no pin	
24*	connected to pin 32	GND	ground supply voltage of the IC	
25	OUT	LED-EN	bus error LED of the Ethernet	
26	IN _{Logic}	-Config Mode	signal to start the configuration mode	internally pulled up with 10 kΩ
27	OUT _{Logic}	DbgTX	serial Debug TX	
28	IN _{Logic}	DbgRX	serial Debug RX	internally pulled up with 10 kΩ
29	IN _{Logic}	RX	serial data RX	internally pulled up with 10 kΩ
30	OUT _{Logic}	TX	serial data TX	

31	OUT _{Logic}	TE	transmit enable
32*	GND	GND	ground supply voltage of the IC

* The supply voltage is 5 V +/- 5 %, max. 100 mA DC.

The Ethernet signals are galvanically isolated. The insulation voltage is 1000 Vrms.

	V _{IL}	V _{IH}
IN _{Reset}	< 0.3V / 5mA	> 1.95V / 10µA
IN _{Logic}	< 0.8V / 0.5mA	> 1.95V / 10µA

	V _{OL}	V _{OH}
OUT _{Logic}	< 0.6V / 1mA	> 3.8V / 0.1mA
OUT _{Driver}	< 0.33V / 4mA	> 3.8V / 4mA

3.2.1 -Boot enable

The IC is started in the firmware update mode with the level GND during the power up process. See also chapter 11.

3.2.2 Load out

Strobe signal for the synchronous serial interface. With the positive edge at this output data is taken from the connected shift registers to the physical outputs.

3.2.3 Data out

On this line data is output on the synchronous serial interface. The most significant bit of the data is output first.

3.2.4 Data In

Data is read in on the synchronous serial interface via this signal. The most significant bit of the data is expected first.

3.2.5 Load In

This pin is the strobe signal for the input data of the synchronous serial interface.

3.2.6 Clock

This signal is the clock line for the synchronous serial interface. That signal is equally valid for data input and data output.

3.2.7 -Reset In

- A reset generator (Max 809) is on board; with it in the normal case the reset input is not required. In this case the reset input has to be connected with VCC, in order to avoid interferences (see chapter 3.6).
- If the the customer's application has to initiate a reset of the UNIGATE® IC, then the reset input can also be connected with a reset output of the customer's application instead of connecting it with VCC. Here all specifications of the reset signal, mentioned in chapter 3.2 have to be kept. The reset-impulse is supposed to last at least 10 ms.

3.2.8 LED-EN

A red LED can be connected to this line (see chapter 3.6). It goes out in the state „Ethernet ok“.

3.2.9 -Config Mode

If the pin has the level GND, then the IC starts in the configuration mode.

3.2.10 DbgTX, DbgRx

They are transmission line and receive line as well of the IC's Debug-interface. For the function description of the Debug-interface see chapter 6.

3.2.11 TE

The transmit enable signal allows the connection of RS485 drivers to the IC's serial interface. The signal is set to 5V whenever the IC sends via the line TX.

3.2.12 TX, RX

Transmission and receive line of the serial interface. This interface is programmable in accordance with the description in chapter 4.

3.3 Software

The software executes script-commands, which in turn control the IC's hardware and they process their complete protocol by software. The script itself can be generated by the company Deutschmann Automation or with the software Protocol Developer by yourself. For a detailed description of the script.commands of the Protocol Developer see the instruction manual Protocol Developer and the online documentation concerning script-commands.

3.4 Basic line of proceeding

In theory it is enough to replace the RS232-driver that is included in your application by the UNIGATE® IC.

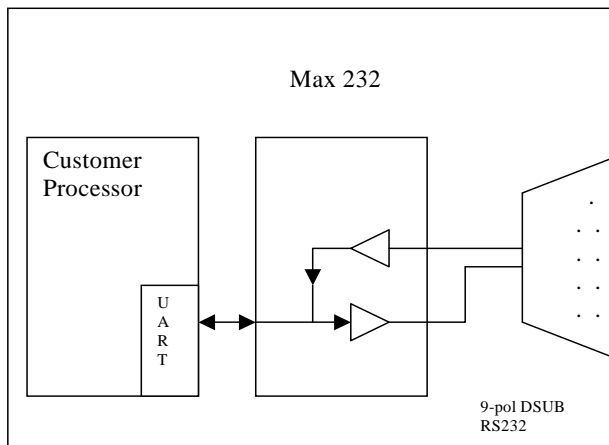

Your device, which on the whole is supposed to be assembled as shown above, will now be modified in a way that the Ethernet is available at the 9-pol. socket. However, a hardware redesign is necessary in order to keep the assignment in standard form.

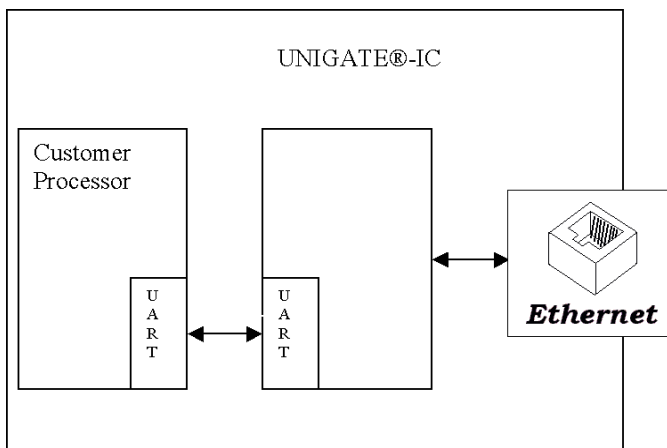

After the RS232-driver has been replaced by the UNIGATE® IC, Ethernet is available at an RJ45-socket.

Deutschmann Automation is also offering an appropriate adapter board. With it existing devices can be adapted without re-design; see chapter 13.

3.5 Connection examples

Here you will find some advise that offers help for a re-design. In the following several versions are listed, that should make it easier for you to decide.

Version 1: Use as a pure link module for the bus

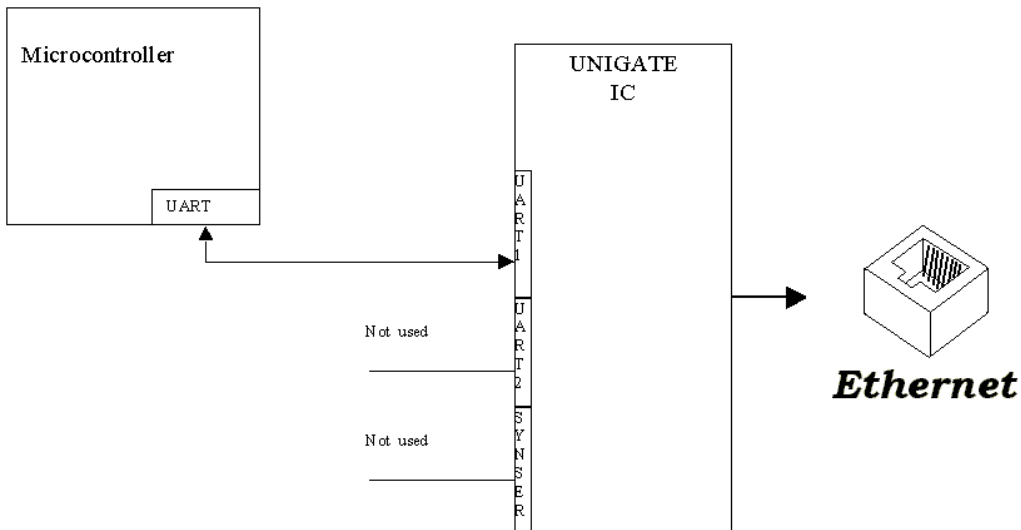

The UNIGATE® IC independently processes the communication with the customer's device via the TTL-interface.

Version 2: Use of UNIGATE® IC for digital or analog I/O-modules

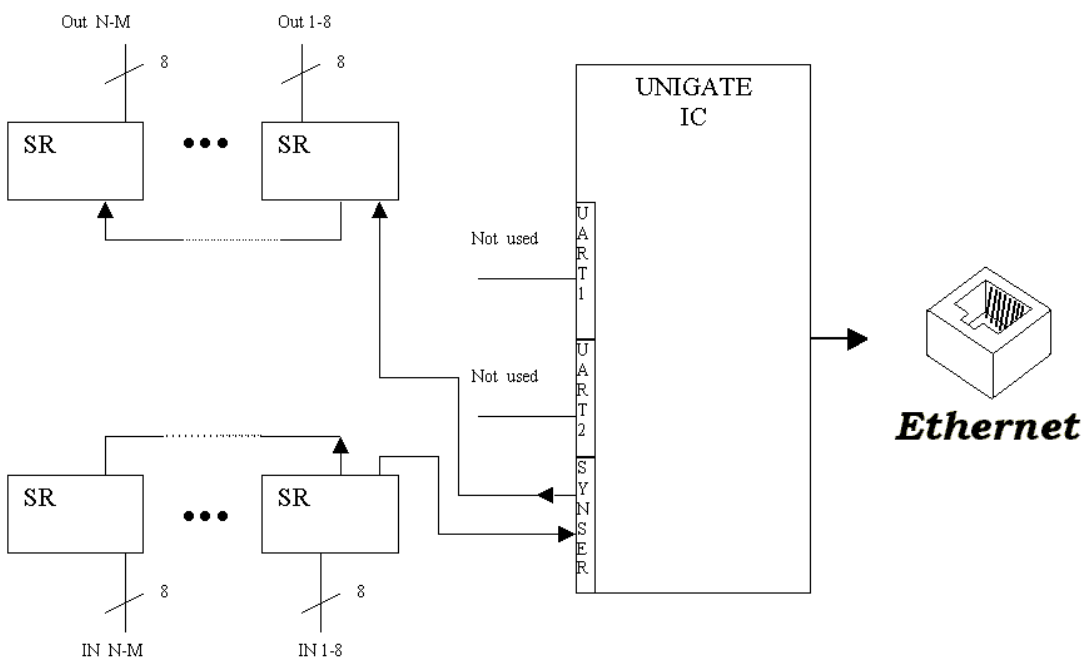

Here only the synchronous serial interface is used, the asynchronous serial interface is basically of no account. If you want to program the script in your completed application, then the use of a connector for the asynchronous interface is recommended. With it you can carry out the ISP-programming.

For this operating mode no additional controller is required on your application!

The following circuit diagram is an example for how shift register components can be connected to the IC.

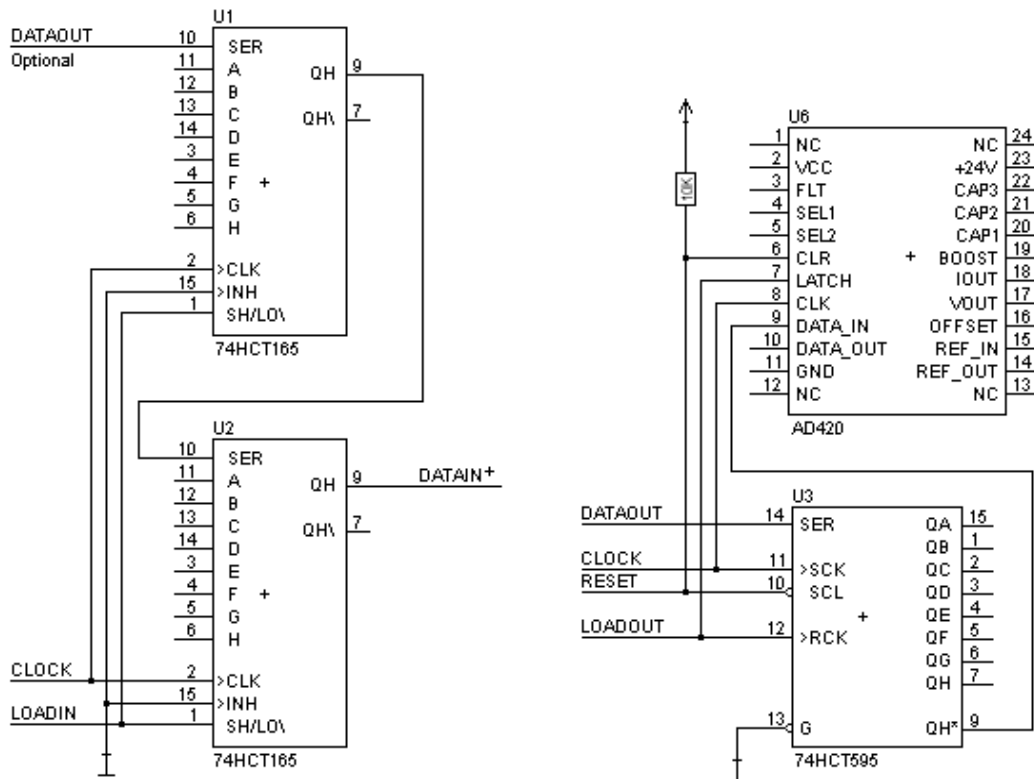

Version 3: Example for digital I/Os

The serial synchronous and the asynchronous interface as well can be operated by UNIGATE® IC at the same time. Here the possibility results that an existing application can be extended by additional digital or analog I/Os.

In chapter 5.2 you find an example for a script, that operates these I/Os.

Valid for all versions: A planned plug connection of the serial interface in the application offers the possibility of an update of the firmware or the software via an external connection.

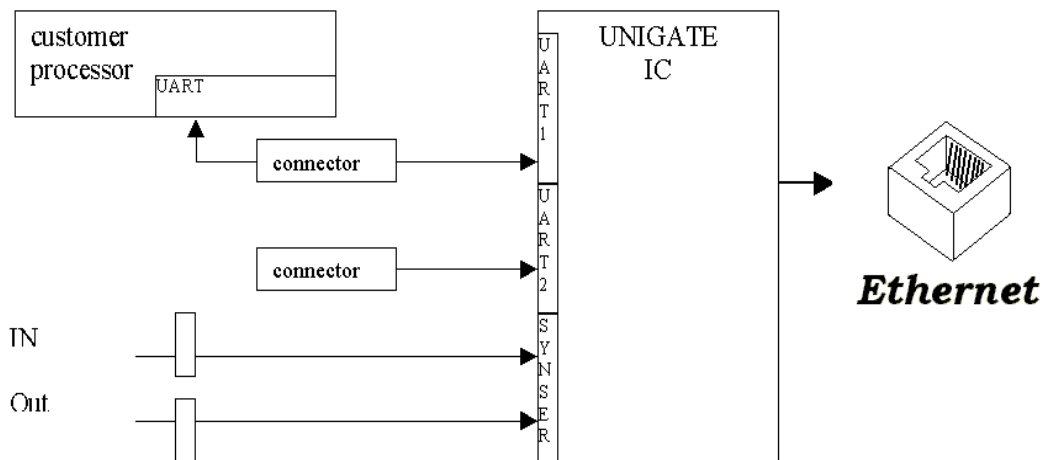

3.6 Layout examples

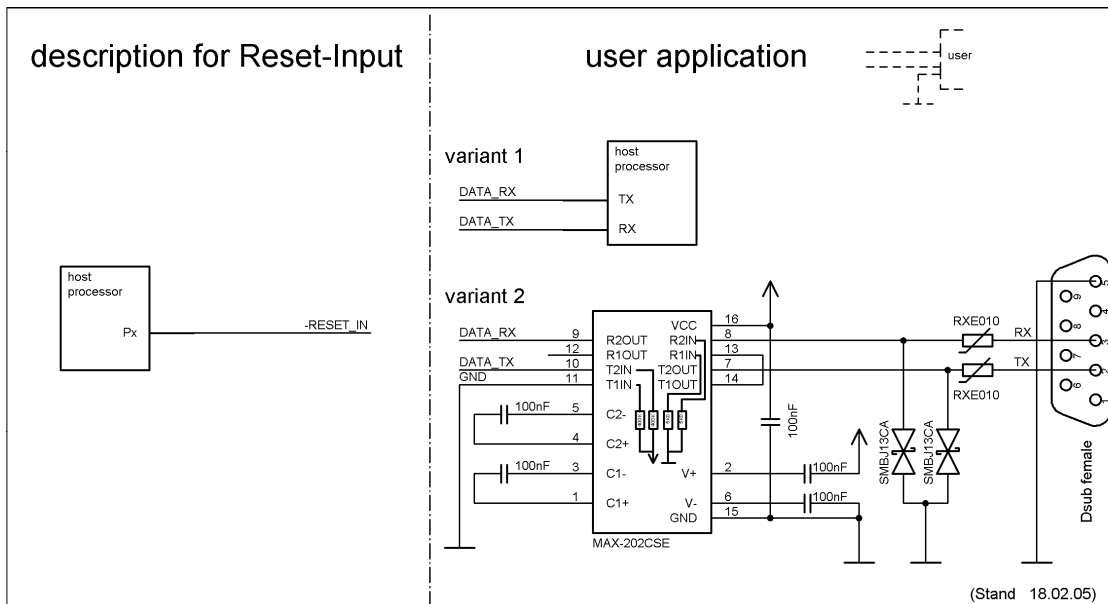
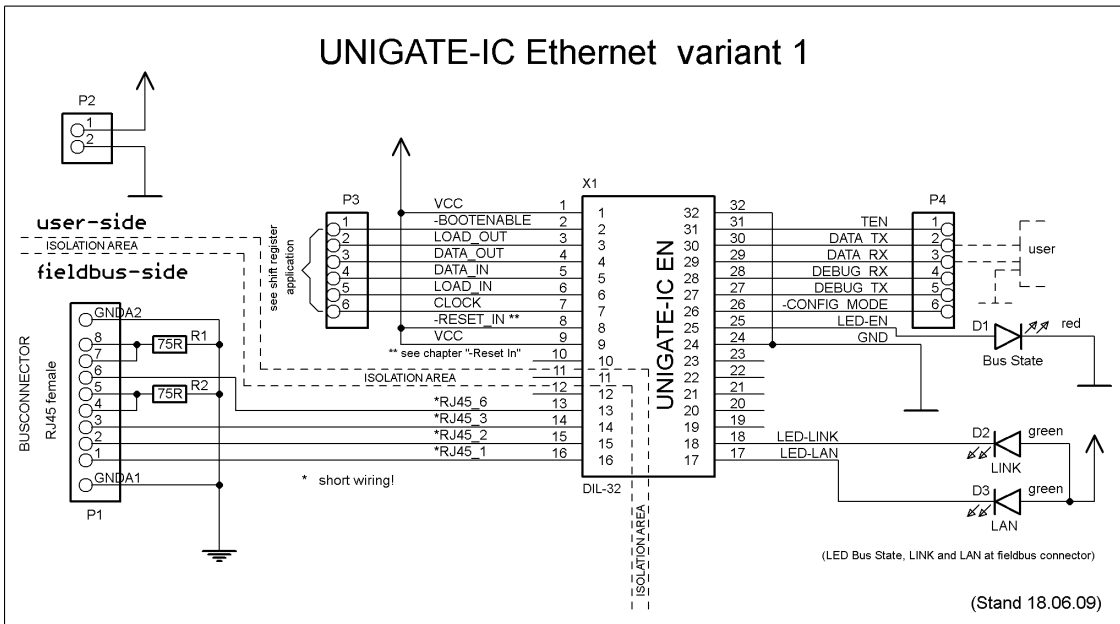

shift register application

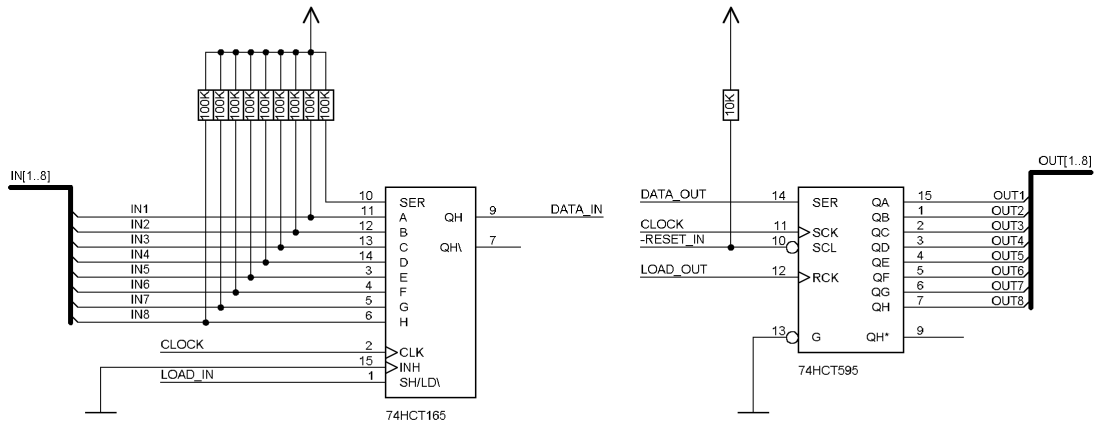

(Stand 26.08.02)

3.7 Handling (mounting the UNIGATE IC® on the carrier board)

Depending on the application and the expected shock- and vibration-conditions you can choose from the following possibilities for the UNIGATE® IC's installation on the carrier board:

- Mounting on a socket in the carrier board. If necessary solder the UNIGATE® IC to 2 or 4 pins in the socket. Normally the IC can easily be pulled out after the soldering points have been removed.
- Make arrangements for two holes next to the socket in the layout. After the UNIGATE® IC was plugged in the socket pull an isolated wire over the IC and solder it on the carrier board at the specified holes.
- Fasten the UNIGATE® IC With a wire or a tie wrap on the socket.
- Manual soldering directly on the carrier board.
- Automatic soldering directly on the carrier board, whereas „selective“ soldering is essential (no wave soldering)

The advantage of the socketed variant is the easy download of Script- and Firmware-updates, if the carrier board is not designed for it. Besides, that way the Fieldbus can be changed easily by changing the UNIGATE® IC if the corresponding plug connectors are provided on the carrier board. Another advantage is, that - normally - only a reflow soldering of the carrier board is necessary.

The advantage of the soldered variant is, that the installation height is lower and a higher shock- and vibration-safety is provided.

4 The serial interface

4.1 Overview

The serial interface is the most important connection between the UNIGATE® IC and the micro controller of your application. The interface is designed in a way so that your application at least does not have to be changed on the software-side. The wide range of services of the UNIGATE® IC's serial interface constitutes the basis for it. The UNIGATE® IC allows to connect of controllers with a baudrate of 110 baud to 625 kbaud. The baudrate for the communication itself is permanently stored in the module. The maximum size for IO-data can be read-out with the Script command "Get RSOutBufFree16".

Depending on the read-in Script of the UNIGATE® IC, the module carries out actions independently, in order to identify data from the connected device. For customers who already have a software-adaptation at the company Deutschmann Automation, this protocol as well or a Script after an adaptation can be processed by the IC.

Anyway, the IC will take over the communication with the fieldbus independently.

4.2 Initialization of the serial interface

The initialization of the interface is carried out by script-commands, such as "Set baudrate", "Set databits", "Set parity". For a detailed description of these commands see the online documentation for the Protocol Developer or the instruction manual for the Protocol Developer.

4.3 Use of the serial interface

The serial interface can freely be programmed by the user. Efficient script-commands for sending and receiving data are available; just to mention some possibilities: such as waiting with timeout for a character, waiting for a fixed number of characters or also sending and receiving data in the Modbus RTU. A reference to these commands is offered in the online documentation for the Protocol Developer as well as in the instruction manual for the Protocol Developer.

4.4 Further operation modes

In the modes configuration mode and firmware-update mode the serial interface also serves to configure the standard software or to carry out a firmware-update. More details can be found in chapter 11.5.

5 Synchronous interface

5.1 Overview of the synchronous serial interface

The synchronous serial interface is an interface of the IC to clocked shift registers. About this it is not only possible to input or output digital signals but also the addressing of DA- or AD-converters with clocked serial interface is possible as well as the connection of LEDs or reading in rotary switches. Connection examples are stated in chapter 3.

The synchronous serial interface can also be used in products, that do not feature an own micro controller (stand alone operation), in order to realize digital IO-modules for instance. Up to 256 signals for input and output each can be processed. The UNIGATE® IC's firmware is responsible for the different amount of input and output signals and takes on control for it.

The data exchange with the script is made with the commands "Set ShiftRegisterInputType / Set ShiftRegisterOutputType" and "Set ShiftRegisterInputBitLength / Set ShiftRegisterOutputBitLength" and "WriteShiftRegister" as well as "ReadShiftRegister".

In order to make the use of the synchronous serial interface as efficient as possible, it is possible to set a „shift register“ and a „bit length“ via the script, whereas both can be changed dynamically within the script by script commands.

As a result the firmware is in the position to control the entire data transfer with the hardware and the data exchange can be carried out as quickly as possible.

At present the shift register types "RiseClk_RiseLoad" and "RiseClk_LowLoad" are implemented, that are required when using for instance the 74595 and 74165 (see also chapter 5.2).

Other types can be complemented very fast and simple - by Deutschmann Automation GmbH.

The shift register type defines the edges or the levels on how data is output to the hardware or how data is read in.

In this case the data exchange is restricted to the script commands "WriteShiftRegister" and "ReadShiftRegister". The clock speed is min. 150kHz, so that for instance a shift register with 32 bit is read in or written in a time period of max. 215µs.

5.2 Script-example

```
var InBuffer: Buffer[2];
Var OutBuffer: Buffer[2];
MoveConst (OutBuffer[0], #0x58#0x21 ),

Set ( ShiftRegisterInputType , RiseClock_FallLoad ) ;
Set ( ShiftRegisterOutputType , RiseClock_RiseLoad ) ;

Set ( ShiftRegisterInputBitLength , 16 ) ;
Set ( ShiftRegisterOutputBitLength , 16 ) ;

WriteShiftRegister ( OutBuffer[0] ) :
ReadShiftRegister ( InBuffer[0] ) ;

// Input data is now in the InBuffer
// 0x58 is applied to the outputs of the analog converter
// 0x21 at the shift register's outputs
```

6 The Debug-interface

6.1 Overview of the Debug-interface

The UNIGATE® IC features a Debug-interface, that allows a step-by-step processing of a script. Normally this interface is only required for the development of a script.

6.2 Starting in the Debug-mode

When applying power to the UNIGATE® IC (power up) the firmware will output the binary character 0 (0x00) after a self-test was carried out on this interface. If the IC receives an acknowledgement via this interface within 500 ms, it is in the Debug-mode. The acknowledgement is the ASCII-character O (0x4F).

With the start in the Debug-mode the further execution of script-commands will be put to a stop.

6.3 Communication parameter for the Debug-interface

The Debug-interface is always operating with 9600 baud, no parity, 8 data bit, 1 stop bit. It is not possible to change this parameter in the Protocol Developer. Please consider the fact that these settings have to be in accordance with those of the PC-COM-interface and that the flow control (protocol) has to be set on „none“ there.

6.4 Possibilities with the Debug-interface

Usually the Protocol Developer is connected to the Debug-interface. With it a step-by-step processing of a script, monitoring jumps and decisions and looking at memory areas is possible. Moreover breakpoints can be set. It basically possesses all characteristics a software-development tool is typically supposed to have. However, it is also possible to carry out a Scrip-update via this interface.

6.5 Commands of the Debug-interface

The commands for the use of the Debug-interface are described in the instruction manual Protocol Developer.

7 Script and configuration

7.1 Overview

In the configuration mode the scripts and configurations, stored in the UNIGATE® IC, can be replaced or updated via the serial interface.

7.2 The configuration mode

If the pin „ConfigMode“ pulled to GND during the PowerUp or Reset, then the UNIGATE® IC starts in the configuration mode. In this mode it is possible to communicate with the IC without processing the regular software. In this mode it is possible to change the UNIGATE® IC's settings of the standard software or to write a new script in the UNIGATE® IC. It shows its start in the configuration mode by issuing a status message, which might look as follows:

```
IC-EN-SC V3.41[18] (c)dA Script="FPGA-Transfer" Author="(dA) GL" Version="V 1.0"  
Date=20.8.2002 SN=47110001.
```

The configuration of a UNIGATE® IC is restricted to setting the Ethernet-address (see also chapter 9 'Setting the Ethernet-address').

7.3 Update the script

The preferred version is the one, where the IC is inserted into the basis board, available from Deutschmann Automation and the Deutschmann tools (e. g. software WINGATE with "Write Script" under "File") are used.

On request the procedures, how to overwrite the included script can be disclosed by Deutschmann Automation in order to automatically replace the script in an application.

7.4 Configuration of the UNIGATE® IC

UNIGATE® IC is delivered with an empty script.

The configuration of the UNIGATE® IC - Ethernet is restricted to the setting of the Ethernet-address.

7.4.1 Ethernet

- Protocol (UPD/IP or TCP/IP)
- Diagnostic data: Max. 8 bytes (see chapter Error handling)
- Baud rate: 10 MBaud
- IP-address (gateway)
- Ethernet (MAC-address)
- IP-destination host

7.4.2 RS232/RS485/RS422

- RS-type: RS232
- Start bit: 1
- Data bits: 8
- Stop bit: 1
- Parity: None
- Baud rate: 9600 Baud
- Default setting. This configuration can be changed via the Script.

8 Generating a script

8.1 What is a script?

A script is a sequence of commands, that are executed in that exact order. Because of the fact that also mechanisms are given that control the program flow in the script it is also possible to assemble more complex processes from these simple commands.

The script is memory-oriented. It means that all variables always refer to one memory area. While developing a script you do not have to take care of the memory management though. The Protocol Developer takes on this responsibility for you.

8.2 Memory efficiency of the programs

A script command can carry out e. g. a complex checksum like a CRC-16 calculation via data. For the coding of this command only 9 byte are required as memory space (for the command itself). This is only possible when these complex commands are contained in a library.

A further advantage of this library is, that the underlying functions have been in practical use for a couple of years and therefore can be described as 'void of errors'. As these commands are also present in the native code for the controller, at this point also the runtime performance of the script is favorable.

8.3 What can you do with a script device?

Our script devices are in the position to process a lot of commands. In this case a command is always a small firmly outlined task. All commands can be put into classes or groups. A group of commands deals with the communication in general. This group's commands enable the gateway to send and receive data on the serial side as well as on the bus-side.

8.4 Independence of buses

Basically the scripts do not depend on the bus, they are supposed to operate on. It means that a script which was developed on a Profibus gateway can also be operated on an Interbus without changes, since the functioning of these buses is very similar. In order to also process this script on an Ethernet gateway, perhaps further adjustments have to be made in the script, so that the script can be executed reasonably.

There are no fixed rules how which scripts have to operate properly. When writing a script you should take into account on which target hardware the script is to be executed, so the necessary settings for the respective buses can be made.

8.5 Further settings at the gateway

Most devices require no further adjustments, except for those made in the script itself. However, there are also exceptions to it. These settings are made by means of the software WINGATE. If you know our UNIGATE®-series, you are already familiar with the proceeding with it. An example is the adjustment of the IP-address and the net-mask of an Ethernet-gateway. These values have to be known as fixed values and are not available for the runtime. Another reason for the configuration of the values in WINGATE is the following: After an update of the script these values remain untouched, i. e. the settings that were made once are still available after a change of the script.

Only this way it is also possible that the same script operates on different Ethernet-gateways, that feature different IP-addresses.

8.6 The use of the Protocol Developer

The Protocol Developer is a tool for an easy generation of a script for our script gateways. Its operation is exactly aimed at this use. After starting the program the script that was loaded the last time is loaded again, provided that it is not the first start.

Typical for Windows script commands can be added by means of the mouse or the keyboard. As far as defined and required for the corresponding command, the dialog to the corresponding command is displayed, and after entering the values the right text is automatically added to the script. The insertion of new commands by the Protocol Developer is carried out in a way that existing commands will not be overwritten. Generally a new command is inserted in front of the one where the cursor is positioned. Of course the commands can also be written by means of the keyboard or already written commands can also be modified.

8.7 Accuracies of the baud rates at UNIGATE® IC

The baud rate of the serial interface is derived from the processor's crystal frequency.

Meanwhile all Script-gateways are working with a crystal frequency of 40 MHz.

You can enter any desired integer baud rate into the script. After that the firmware adjusts the baud rate, that can be derived the most precisely from the crystal frequency.

The baud rate the gateway is actually working with (BaudIst) can be determined as follows:

$$\begin{aligned} \text{BaudIst} &= (\text{F32} / \text{K}) \\ \text{F32} &= \text{Crystal frequency [Hz]} / 32 \\ \text{K} &= \text{Round}(\text{F32} / \text{BaudSoll}); \\ &\quad \text{Round}() \text{ is a commercial roundoff} \end{aligned}$$

Example:

The actual baud rate is to be calculated, when 9600 baud are pre-set, where the gateway is operated with 40 MHz:

$$\begin{aligned} \text{F32} &= 40000000 / 32 = 1250000 \\ \text{K} &= \text{Round}(1250000 / 9600) = \text{Round}(130.208) = 130 \\ \text{BaudIst} &= 1250000 / 130 = 9615.38 \end{aligned}$$

I. e.: The baud rate actually adjusted by the gateway is 9615.38 baud

The resulting error in per cent can be calculated as follows:

$$\text{Error}[\%] = (\text{abs}(\text{BaudIst} - \text{BaudSoll}) / \text{BaudSoll}) * 100$$

In our example the following error results:

$$\text{Error} = (\text{abs}(9615.38 - 9600) / 9600) * 100 = 0.16\%$$

In practise errors below 2% can be tolerated!

In the following please find a listing of baud rates at a 40 MHz-crystal frequency with the corresponding errors:

4800 baud:	0.16%
9600 baud:	0.16%
19200 baud:	0.16%
38400 baud:	1.35%
57600 baud:	1.35%
62500 baud:	0%
115200 baud:	1.35%
312500 baud:	0%
625000 baud:	0%

8.8 Script processing times

The Script is translated by the Protocol Developer and the consequently generated code is loaded into the Gateway. Now the processor in the Gateway interprets this code. In this case, there are commands that can be processed very fast (e. g. "Set Parameter"). There are also commands, however, that take longer (e. g. copying 1000 bytes). Consequently, for one thing the processing time differs due to the kind of Script command. But the processing time of the Script commands is considerably more determined by the processor time that is available for this process. Since the processor has to carry out several tasks simultaneously (multitasking system) only a part of the processor's capacity is available for the Script processing. The following tasks - in the order of priority - are executed on the processor:

- Sending and receiving data at the Debug-interface (provided that the Protocol Developer has been started on the PC)
- Sending and receiving data at the RS-interface
- Sending and receiving data at the Fieldbus-interface
- Tasks controlled via internal clock (1 ms) (e. g. flashing of an LED)
- Processing of the Script

From experience approximately 0.5 ms can be calculated for each Script line. This value confirmed itself again and again in many projects as a standard value. He is always quite right if the processor has enough time available for the Script processing.

By means of the tasks mentioned above, the following recommendation can be formulated in order to receive a rather fast Script processing:

- Deactivate the Debug-interface (it is the normal case in the serial use)
- Keep the data length at the RS-interface as small as possible. The baud rate is not the problem here, but the amount of characters which are transferred per second.
- Do not unnecessarily extend the data length at the Fieldbus side. Especially at acyclical bus data, if possible do only send them when changes were made. The data length at buses that are configured to a fixed length (e. g. Profibus) should not be longer than absolutely necessary.

If the processing time should be too large in spite of these measures, there is the possibility to generate a customized Script command, that executes several tasks in one Script command. Please contact our support department for this purpose.

9 Setting the Ethernet-address

Setting the address through the configuration

The UNIGATE® IC has to be in the configuration mode (see also chapter 7.2 'The configuration mode'). With WINGATE it is now possible to set the address. This address is preserved until it will be changed again.

Script example for the initialization of the Ethernet

```
var InSize: word;
var OutSize: word;

Set ( EN_SOURCE_PORT , 2000 ) ;
Set ( EN_Destination_Port , 2000

BusStart;
// the Ethernet ASIC is ready now.
// from now on the Master CAN configure the participant.
// However, that does not mean that the configuration of the
// participant has already been carried out by the Master.

wait (Bus_Active);
// the Ethernet is now in the state of Data Exchange
// This command might take a very long time and is
// not interruptible!
// Now it is also known to the Script with which configuration
// the Slave was put into operation by the Master.

Get ( BusInputSize, InSize);
Get ( BusOutputSize, OutSize);
// InSize and OutSize are from the IC's point of view!

// It is possible to read out data from the bus
// all available bytes should be read.
var InBuffer: Buffer[100];
Readbus ( InBuffer[0], InSize) ;

// It is now possible to write data.
// You must not write more bytes than available.
var OutBuffer: Buffer[100];
WriteBus ( OutBuffer[0], OutSize );
```

10 Error handling at UNIGATE® IC

A distinction can be made between two categories of system-errors:

Serious errors (1-4): In this case, the Gateway must be switched off and switched back on again. If the error occurs again, the Gateway must be exchanged and returned for repair.

Warnings (6-15): These warnings are displayed for one minute simply for information purposes and are then automatically reset. If such warnings occur frequently, please inform After-Sales Service.

The system-error can be read-out via the Script.

In the configuration mode these displays are not valid and only meant for internal use.

Error no.	Error description
0	Reserved
1	Hardware fault
2	EEROM error
3	Internal memory error
4	Fieldbus hardware
5	Script error
6	Reserved
7	RS-transmit buffer overflow
8	RS-receive buffer overflow
9	RS timeout
10	General fieldbus error
11	Parity-or frame-check-error
12	Reserved
13	Fieldbus configuration error
14	Fieldbus data buffer overflow
15	Reserved

Table 1: Error handling at UNIGATE® IC

11 Firmware-update

11.1 Overview

UNIGATE® IC has a 64 kbyte flash memory for the firmware. In the firmware-update-mode the firmware can be replaced via the UNIGATE® IC's serial interface.

11.2 Starting in firmware-update-mode

11.2.1 Adjustment by hardware

UNIGATE® IC can be brought to the firmware-update-mode by the hardware. For it the signal -BE (boot enable) has to be pulled to the potential GND during the Power-up-process.

11.2.2 Adjustment by software

If the UNIGATE® IC is in the configuration mode (see chapter 7.2) it can be brought to the firmware-update-mode interactively through the command CTRL-F (0x06). After sending the command a security query follows, that has to be answered with J or N (J = Yes, N = No). After a positive confirmation the IC is re-started in the firmware-update-mode.

11.3 Execution of the firmware-update

The safest way for the firmware-update is the use of the basic board combined with the software "FDT.EXE" (firmware-download-tool). These tools are available from Deutschmann Automation (see chapter 13).

It is also possible to use the description and the tools of the manufacturer of the controller (TEMIC, 89C51RD2) as well.

11.4 Note on safety

The firmware-update should only be carried out when there is no other possibility left. A firmware-update-process that has already been started CANNOT be undone. With it the previously used firmware is permanently unusable.

11.5 Operation mode of the IC

Standard-operation mode

This mode is required for the regular use of the IC. In this mode the IC will process all script-commands and normally exchange the corresponding user data. The bus as well is operated in this mode through the IC.

Configuration mode

In the configuration mode the UNIGATE® IC will carry out a self-test after the start (or after a reset). After a successful self-test it will wait for further commands. Here it is possible to load a translated Script into the unit or to initialize the firmware-download-mode.

12 Technical data

In this chapter you will find all necessary technical data on UNIGATE® IC.
All measurements in mm.

12.1 Mechanics of the UNIGATE® IC

12.1.1 General dimensions of UNIGATE® IC

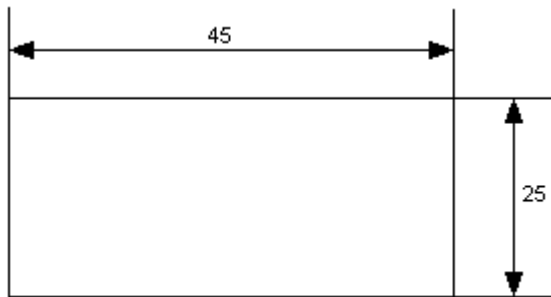

Max. height = 20 mm, including pin

12.1.2 Dimensions UNIGATE® IC (Ethernet only)

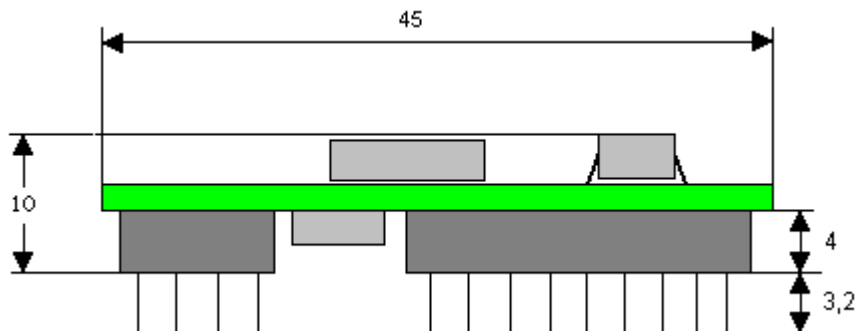

The pins of UNIGATE® IC - Ethernet are arranged with a grid spacing of 2.54 mm.

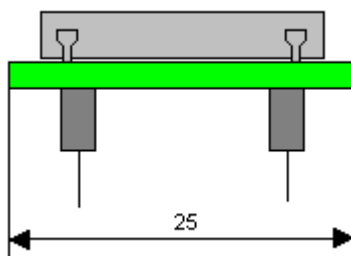

DIP-Spacing Code 6

In case you intend to use other fieldbus ICs, the maximum overall height of ≤ 20 mm (including pins) has to be taken into consideration.

12.2 Technical data UNIGATE® IC-Ethernet

Characteristics	Explanation
Supply voltage	5 V ± 5 %, max. 100 mA DC
Interface	2 UART interfaces, 1 synchronous serial interface
Physical separation Ethernet-side	Standard
TCP/IP baud rate	Adjustable 10 MBaud)
UART-baud rate	Up to 625 Kbaud (adjustable via script)
Supported Ethernet protocols	UDP, TCP/IP
Technology	CS8900
Others	I/Os, analogous signals, shift registers, LEDs, switches and so on can be connected externally
Dimensions	45 x 25 x 10 mm (WxDxH)
Installation	32 DIL
Weight	Approx. 9 g
Operating temperature	-40°C ..+85°C
Storage / transport temperature	-40°C..+100°C
Built-in position	Any

13 Accessory

The following tools are available from Deutschmann Automation.

13.1 Adapter RS232

In an application the adapter RS232 offers the possibility to replace an existing driver MAX 232 (only in DIL-16-housing) by this adapter. This board allows the use of the IC according to chapter 3.4 on page 15. Please note that with it the Ethernet does not offer a connection conforming to the standards. With a plug adapter, however, at least the operation of Ethernet is possible.

The hardware is only meant for development purposes. It offers the possibility to make an existing application capable for bus connection in no time and to test the IC's utilizability and functionality.

13.2 Adapter RS485

From the functionality's point of view the RS485 adapter is the same as the RS232 adapter. It offers the possibility to replace a module LS 176 (only in DIL-8-housing) by the IC.

There are the same restrictions as for the RS232 adapter.

13.3 FirmwareDownloadTool (FDT)

The FirmwareDownloadTool is available for download from our homepage: it is required for an update of the firmware. Condition for it is, that a PC can be connected to the serial of the IC. The software describes the procedure of an update itself.

13.4 Protocol Developer

The Protocol Developer is the development environment for scripts, that also contain the Debugger. This software package also contains the documentation to all script-commands. This software is available for download from our homepage at <http://www.deutschmann.com>. The instruction manual for the Protocol Developer, which is available in pdf-format, gives further advise on how to use the software.

13.5 Developerkit UNIGATE® IC-AB IC

The Developerkit IC contains

- a Developerboard UNIGATE® IC (see chapter 13.5.1)
- a plug-in power pack to supply the Developerboard
- connection cables for appl. RS232, Debug RS232 and appl. RS422/485
- USB-cable
- Software and documentation to complete the packet.

13.5.1 Developerboard UNIGATE® IC-AB

The Developer Board was developed so that the fast implementation of the Deutschmann All-in-one bus node UNIGATE® IC into your electronic system can be guaranteed. The board is suitable for all Fieldbuses and Industrial Ethernet Buses supported by Deutschmann Automation.



The required UNIGATE® IC / ICs are ordered separately. The required voltage (5V or 3.3V, depending on the version) can be adjusted. An RS232-interface or a USB-connection is available for the connection to the PC (Debug-interface). The application can be connected either through the USB, RS232, RS485 or the RS422. The bus-connections according to standard or market standard are available to test the respective bus-side. Optionally Deutschmann Add-on packages (bus-master simulation) are available. The board contains 32 bit input and 16 bit output, provided with one LED each. Different connectors allow an easy coupling to your processor. A hole matrix field with the most important signals (voltage, IOs) allows a customized hardware extension (e. g. to connect a D/A converter).

13.5.2 Quick start

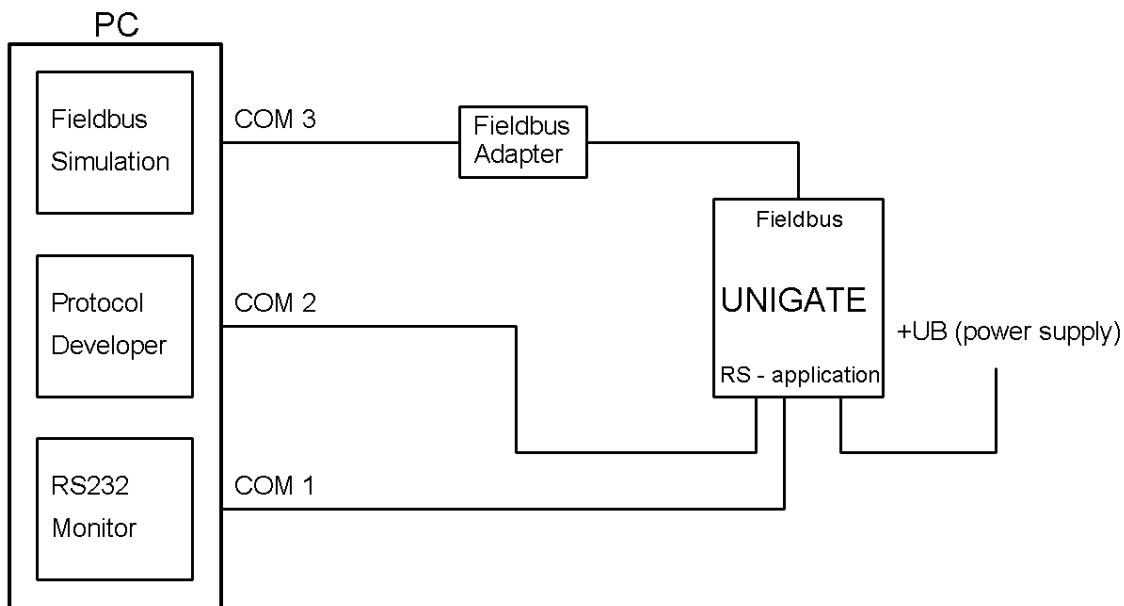

For a transparent data exchange you will find example scripts for the respective Fieldbus under "File->New" in the Protocol Developer.

14 Appendix

14.1 Explanations of the abbreviations

General

CL	=	Product group CL (Compact Line)
CX	=	Product group CX
FC	=	Product group FC (Fast Connect)
GT	=	Galvanic separation RS-side
GY	=	Housing color gray
RS	=	Product group RS
SC	=	Product group SC (Script)
232/485	=	Interface RS232 and RS485 switchable
232/422	=	Interface RS232 and RS422 switchable
DB	=	Additional RS232 DEBUG-interface
D9	=	Connection of the RS through 9-pin D-SUB instead of 5-pin screw-plug connector
PL	=	Board only without DIN-rail module and without housing cover
PD	=	Board only without DIN-rail module and with housing cover
AG	=	Gateway installed in a die-cast aluminum housing
EG	=	Gateway installed in a stainless steel housing
IC	=	Product group IC (IC-design DIL32)
16	=	Script memory expanded to 16KB
5V	=	Operating voltage 5V
3.3V	=	Operating voltage 3.3V

Fieldbus

ASI	=	AS-Interface (AS-i)
BI	=	BACnet/IP
BMS	=	BACnet MSTB
CO	=	CANopen
C4	=	CANopen V4
C4X	=	CANopen V4-version X (see comparison table UNIGATE® IC for the respective product)
DN	=	DeviceNet
EC	=	EtherCAT
EI	=	Ethernet/IP
FE	=	Ethernet 10/100 MBit
FEX	=	Ethernet 10/100 MBit-version X (see comparison table UNIGATE® IC for the respective product)
IB	=	Interbus
IBL	=	Interbus
LN62	=	LONWorks62
LN512	=	LONWorks512
MPI	=	Siemens MPI®
PL	=	Powerlink
PN	=	Profinet-IO
PBDP	=	ProfibusDP
PBDPL	=	ProfibusDP-version L (see comparison table UNIGATE® IC for the respective product)
PBDPX	=	ProfibusDP-version X (see comparison table UNIGATE® IC for the respective product)

PBDPV0 = ProfibusDPV0
 PBDPV1 = ProfibusDPV1
 RS = Serial RS232/485/422

14.2 basis board

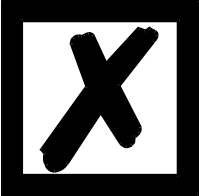

The basis board that is described in this chapter was supplied until the end of 2008.

A new board is available since the beginning of 2009 (see chapter 13.5.1).

14.2.1 Overview basis board Ethernet

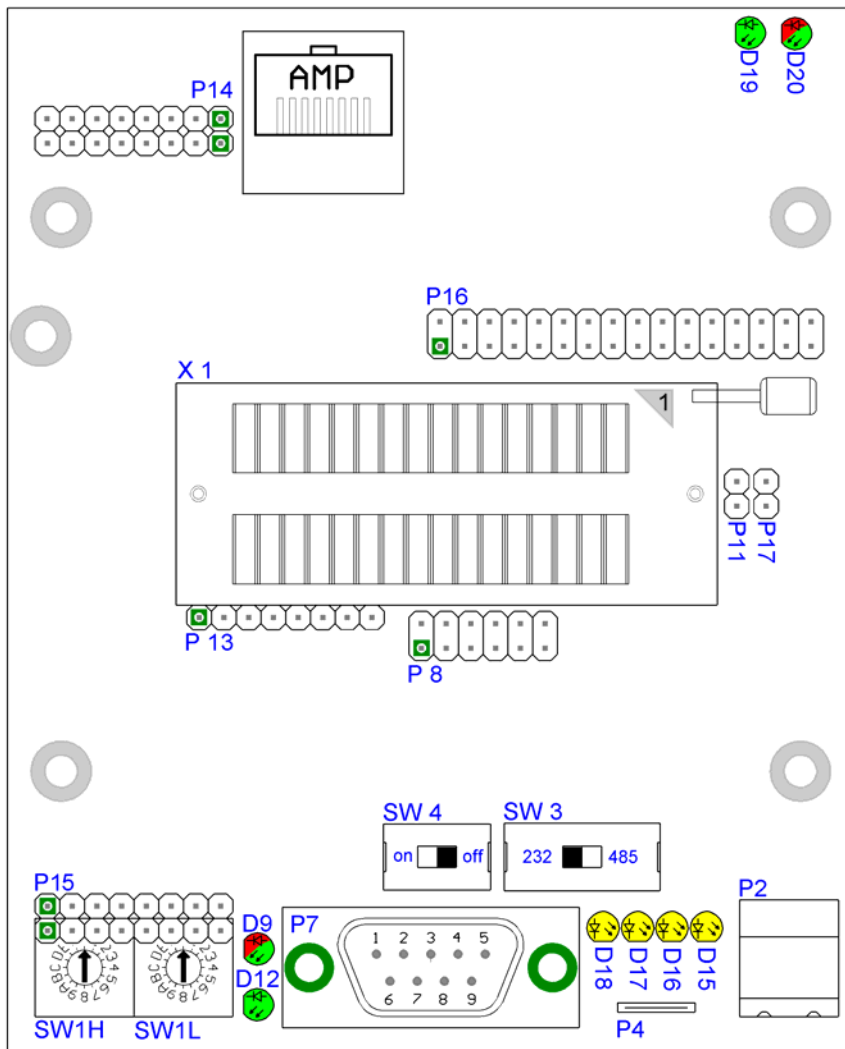

Slot X 1 (ZIF-socket)

PIN 1 of the IC is located up at the lever of the ZIF-socket.

Never place the IC into the socket back to front!

P 2

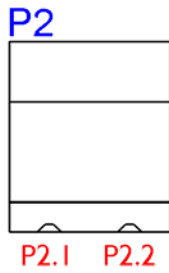

Pin	Signal
Pin 1	24 V DC
Pin 2	Ground

The basis board is supplied with voltage through this plug connector.

P 3

Ethernet plug connector, for the assignment of the connector see chapter 14.2.2.2.

P 4

Earth terminal 6.3 mm for basis board.

P 7

This plug is the basis board's serial connection to the customer's device and the connection to the PC (Debug-interface).

For the pin assignment see chapter 14.2.2.1.

P 8

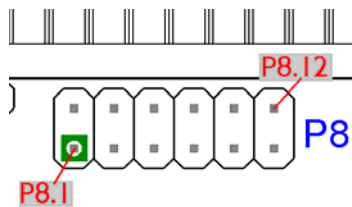

The illustration shows the arrangement of the pins. On this connector strip the signals of the serial connection between IC and RS-drivers are wired. For an initial development you will probably also use an existing driver in your application. In order to exchange it later on, you can also directly take the signals of the serial interface here.

P 11

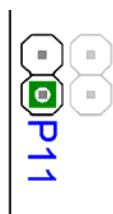

Force Boot. By setting this bridge the Pin BE is dragged to Ground. For the function see chapter 11.2.1.

P 13

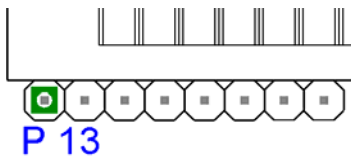

Status signal of the IC
 Plug connector P 13

Pin	Signal
1	Vcc
2	Gnd
3	-RESET
4	RX of the IC (TTL-level)
5	TX of the IC (TTL-level)
6	TE Pin IC (TTL-level)
7	TX Debug of the IC (TTL-level)
8	RX Debug of the IC (TTL-level)

P 14

Input shift register
 For a detailed assignment and for information on which pin is assigned to which bits, see also chapter 5.

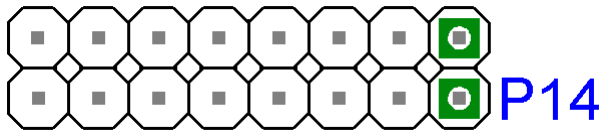

Connection	Pin	Meaning
P 14	1	Input 9

	8	Input 16

P 15, SW1H, SW1L

Input shift register
 Basically the same applies as for P 14, with the exception that different input bits of the shift registers are wire.

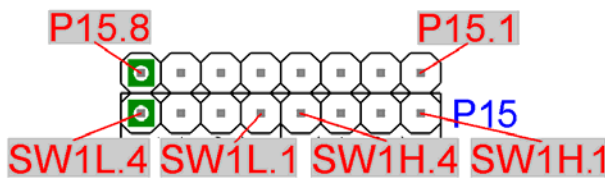

Connection	Pin	Meaning
P 12	1	Input 1

	8	Input 8
SW1H	1	Input 17

	4	Input 20
SW1L	1	Input 21

	4	Input 24

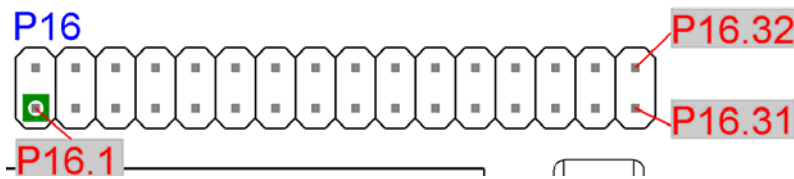
P 16

All digital outputs of the shift registers are available here. Additionally the LEDs D9, D15..D18, D20 are connected to the shift registers.

P 17

With P17 the UNIGATE® IC can be brought into the configmode. If the jumper is plugged and if the UNIGATE® IC is restarted (by power off and power on or by reset), then the UNIGATE® IC will start in the configmode. In order to use the configmode with Deutschmann software tools the interface of the board has to be in RS232-position and the PC has to be connected with the „normal“ interface, where otherwise your application is connected to.

See also chapter 7.2.

SW1H, SW1L, SW5H, SW5L

The rotary switches SW1H, SW1L, SW5H, SW5L are plugged into the base boards and can be removed if required. As a default the rotary switches are plugged in and can be read in through the basis board's shift registers base boards (see also chapter 5 for it).

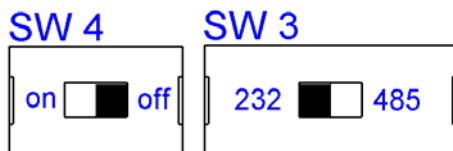
SW3, SW4

These switches are required for the setting of the serial interface. The switch SW3 is used to switch between interface RS232 and RS485. This is the interface, the customer's device is connected to. The Debug-interface always has RS232-level.

The switch SW4 is of importance only, when it is an RS485-interface. Then this switch can be used to connect the termination of the RS485-bus.

Each switch position can be taken from the illustration.

D12

Power LED

This LED is always supposed to be shining statically green when the board is supplied with voltage.

D9, D15..D18, D20

LEDs that are connected to the shift register components. See also (see also chapter 14.2.4 'Wiring diagram UNIGATE® IC-basis board Ethernet').

D19**LED LINK**

This is directly addressed by the Ethernet-controller and signalizes that the UNIGATE® IC is connected to an operable network (LINK-pulses are being received).

14.2.2 Connectors of the basis board**14.2.2.1 Connector to the external device (RS-interface)**

The connection cable to the external device must be plugged in at the connector accessible on the underside of the device.

Pin assignment P7 (9-pin Sub-D, plug)

Pin No.	Name	Function
1		
2	Rx/RS485- / RS422- (Tx)	Receive signal customer's device
3	Tx/RS485+ / RS422+ (Tx)	Transmit signal customer's device
4	Tx / Diag	Transmit signal Debug interface
5	GND RS	Ground connection, reference for PIN 2+3+6+7
6	RS422- (Rx)	
7	RS422+ (Rx)	
8	Not connected	Not connected
9	Rx / Diag	Receive signal Debug interface

**Attention:**

In case the RS-interface is NOT potentially divided, "GND" and "supply 0V" are connected internally.

Pin assignment P2 (2-pin screw-type/plug connector)

Pin No.	Name	Function
1	10.8...30 V / DC	10.8...30 V supply voltage
2	0 V / DC	0 V supply voltage

14.2.2.2 Ethernet connector

The connector for the connection to Ethernet (RJ45) is located on the upper side of the device.

Pin No.	Name	Function
1	TX+	Transmission line+
2	TX-	Transmission line -
3	RX+	Receive line+
4	n. c.	Not connected
5	n. c.	Not connected
6	RX-	Receive line-
7	n. c.	Not connected
8	n. c.	Not connected

14.2.2.3 Power supply of the basis board

The device must be powered with 10.8-30 VDC.

Please note that the devices of the series UNIGATE® with 9-pin D-SUB connector, the power supply is routed via the separate 2-pin screw-type/plug connector.

Please pay attention to the fact that devices of the series UNIGATE® cannot be operated with AC voltage.

14.2.2.4 Shield terminal lead

The shield signal for the electronic circuitry is connected to the top-hat rail via the connector provided. The shield signal for the Ethernet cable shield is not electrically connected to the shield signal of the electronic circuitry for reasons relating to interference immunity.

14.2.3 Rotary coding switches

The rotary coding switches are socketed and can be taken off, in order to alternatively use the pins of the shift register.

14.2.3.1 Slide switch (RS485/RS232 interface)

This slide switch is used to select whether an RS485 interface or an RS232 interface is connected at the connector to the external device.

14.2.3.2 Slide switch (RS485 termination)

If the gateway is operated as the first or last physical device in the RS485 bus, there must be a bus termination at this gateway. In order to do this, either a bus terminating resistor in the connector or the resistor ($150\ \Omega$) integrated in the gateway must be activated. In order to do this, slide the slide switch to position ON. In all other cases, the slide switch must remain in position OFF. Please refer to the general RS485 literature for further information on the subject of bus terminations.

If the integrated resistor is used, please allow for the fact that this also activates a pull-down resistor ($390\ \Omega$) to ground and a pull-up resistor ($390\ \Omega$) to VCC.

At the RS422-interface the transmission line is terminated. The receive line is always firmly terminated.

14.2.4 Wiring diagram UNIGATE® IC-basis board Ethernet

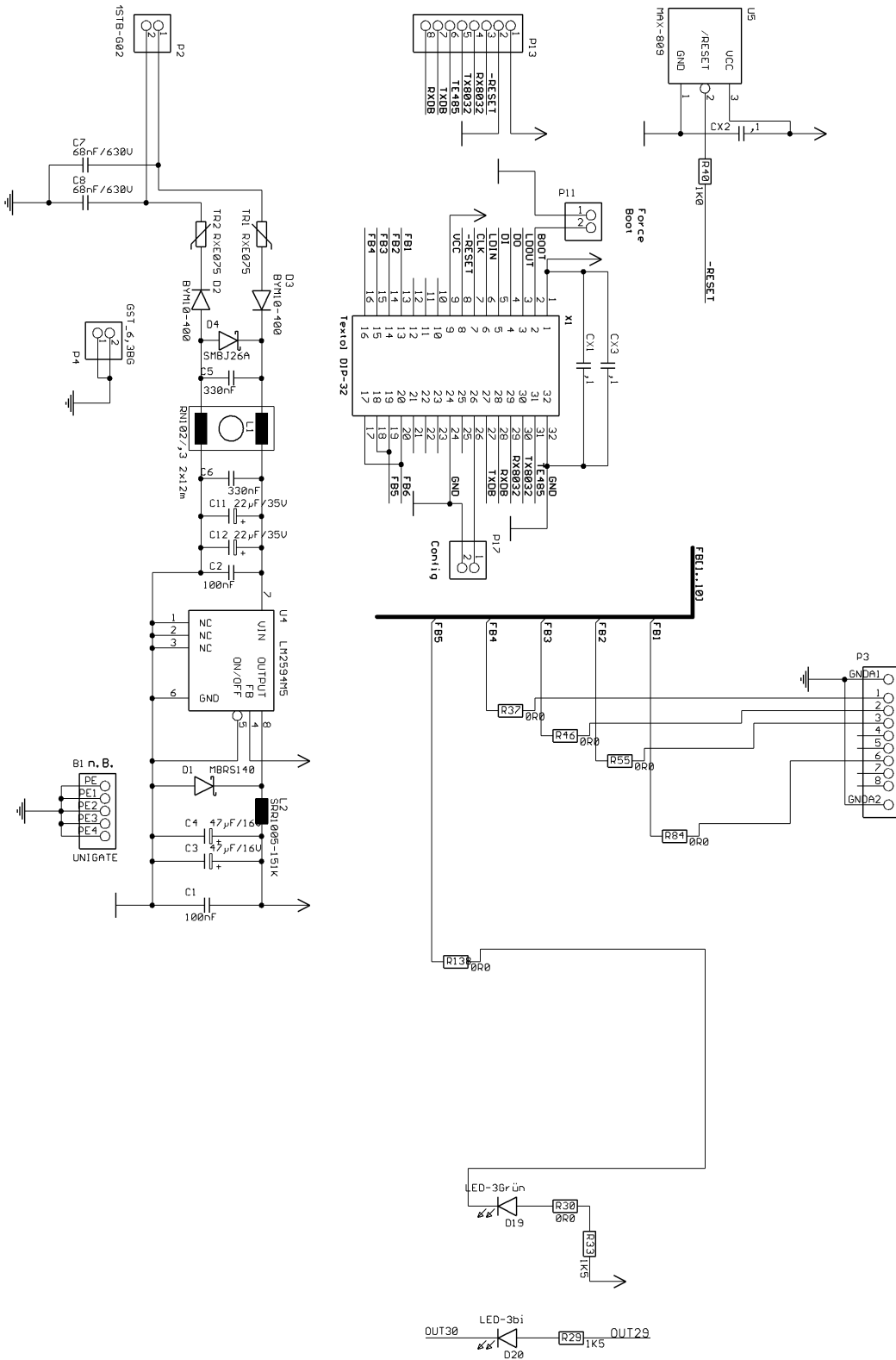

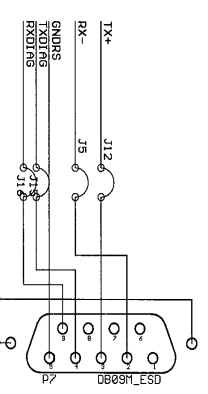
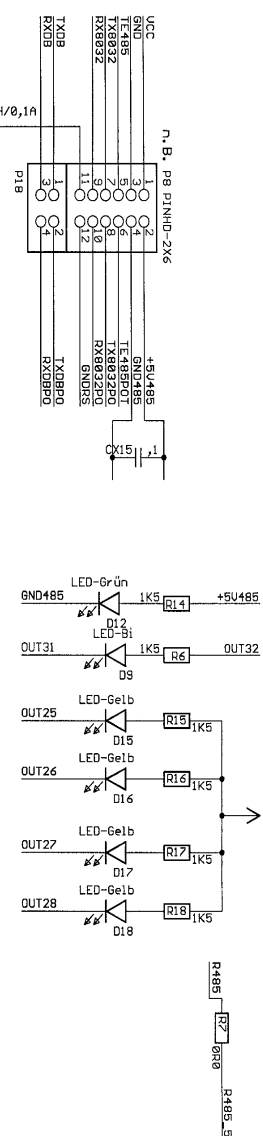
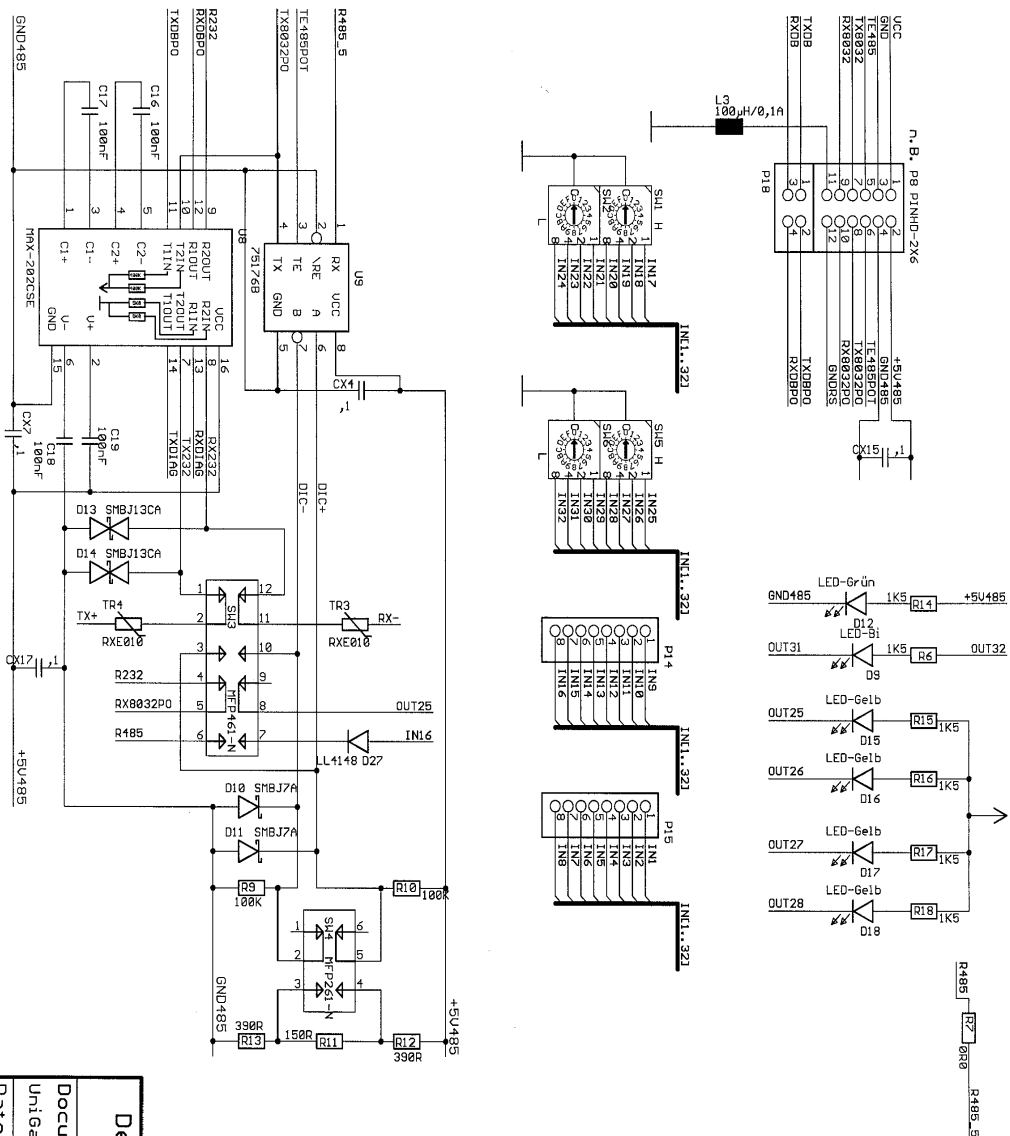

Deuschmann Automation GmbH
 68528 Bad Camberg - Max-Planck-Str. 21
 Tel.: 06434/94330 Fax: 06434/943340

Document:
 UniGate-IC Basis RevA

Date: 16.01.2002 15:15:14 Sheet: 2/3

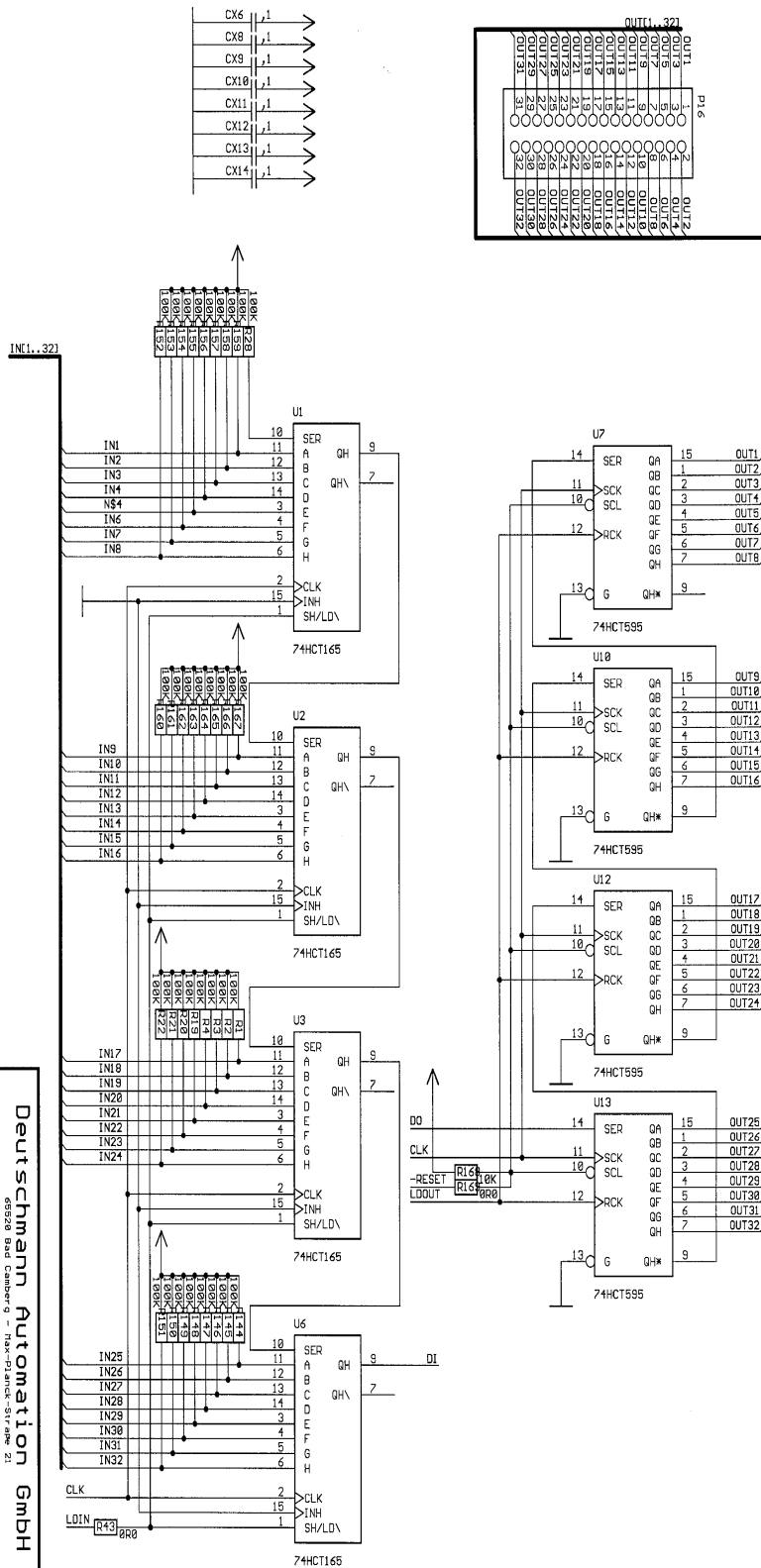

Deutschmann Automation GmbH
 69258 Bad Camberg 9 · Fax: 0434/943340
 Tel.: 0434/94330 Fax.: 0434/943340
 UniGate-IC Basis RevA
 Date: 16.01.2002 15:11:32 | Sheet: 3/3

15 Representation of the data in Ethernet

Each Ethernet-Client processor with TCP/IP network-protocol in a 10 Mbaud Ethernet can exchange data with the gateway.

15.1 Network-addresses, network-connections

After switching on, the gateway is waiting for data communication with a network-participant. In this case the gateway is always prepared to react to ICMP messages (e. g. **PING** Request and Reply). The functions of the ARP-protocol are also available.

15.2 TCP-connection setup

In the characteristic application in the TCP/IP-protocol, after switching on, the gateway is in the state "Passive Open" under an IP-address and port number that was determined in the configuration. A Client processor is in the position to open a TCP/IP connection with the gateway under the port determined in the configuration. After a successful connecting, data can be exchanged.

15.3 Data exchange

At the protocol TCP/IP, a full duplex data connection is available after establishing a connection between the gateway and the attached Ethernet-Client. The data stream is protected by the TCP/IP-protocol in both directions.

When operating with UDP/IP-protocol, no connection is established before data is transferred. In this case the application is responsible for the control of the data flow as well as for the backup of the data.

15.3.1 TCP or UDP?

TCP is a connection-oriented protocol: Here a fixed logical connection between Client and Server exists in the course of the data communication. TCP features all mechanisms, that are required, in order to open a connection and to guarantee a flawless data transfer across the network and then again close the connection. For that reason the protocol software creates and administers own buffers for each connection. In case a lot of UNIGATE-servers are to be addressed from one processor at the same time, storage limits in the processor might result in an extreme case.

In contrast to TCP, UDP does not have mechanisms available to repeat data packets or to check them on their completeness. The data communication with UDP is to be recommended if a parent protocol guarantees a flawless transmission between the terminal device at the UNIGATE-server and the application on the TCP/IP-station anyhow.

15.4 TCP/IP-deviations from the standard

Deviations of the TCP/IP-stack from the conventions from RFC 791, RFC 792 and RFC 793:

1) Deviation from RFC 793 (Multiplexing)

Only an active TCP-session is possible. Depending on the configuration:

- a) A new connection is not permitted.
Gateway is not responding to new SYN-packets.
- b) In case of an already existing connection a new one is made.
The existing connection is not further serviced.
This connection, however, is not closed either.

2) Deviation from RFC 791

An assembling of fragmented IP-datagrams is not carried out. (Reassembling)

3) Deviation from RFC 793

A caching of TCP-segments that were delivered in wrong order is not carried out..

4) Deviation from RFC 791

No support of the Type Of Service (TOS) and security options.

5) Deviation from RFC 793

Incoming TCP-options are ignored.

6) Deviation from RFC 792

Only the information messages ECHO REQUEST and ECHO REPLY are realized.

16 Servicing

Should questions which are not covered in this manual crop up, please contact us directly.

Please note down the following information before calling:

- Device designation
- Serial number (S/N)
- Article number
- Error number and error description

You can reach us during hotline hours which are as follows

Monday to Thursday from 8 am to midday and from 1 pm to 4 pm, Friday from 8 am to midday.

Deutschmann Automation GmbH & Co. KG
Carl-Zeiss-Str. 8
D-65520 Bad Camberg
Germany

Central office and sales department +49-(0)6434-9433-0
Technical hotline +49-(0)6434-9433-33

Fax sales department +49-(0)6434-9433-40
Fax technical hotline +49-(0)6434-9433-44

E-mail technical hotline hotline@deutschmann.de

16.1 Downloading PC software, Script examples etc.

You can download the current version of WINGATE® and Script examples free of charge from our Internet server.

Here you will also find the software tool Protocol Developer for UNIGATE® SC and IC.

<http://www.deutschmann.com>

